

Project

Item #

Quantity



GLOBE FOOD EQUIPMENT COMPANY

Automatic Frozen Meat Slicer

3850PF



3850PF Automatic Frozen Meat Slicer

Model

- 3850P - Two Speed Automatic Frozen Meat Slicer

Features a 13" serrated knife and a high-performance gear drive system specifically designed for this tough application.

Standard Features

- 13" hardened steel alloy serrated knife
- High-performance gear drive system
- Powerful 1/2 HP, 7 amp knife motor
- Independent chute motor
- Exclusive stainless steel construction
- Built in antimicrobial protection
- Precision gear slice thickness adjustment
- EZ-Glide™ adjustable slicing table
- Open space base design
- Knife cover interlock
- Permanently attached knife ring guard
- Full gravity feed, 45° angle
- 3 lb. stainless steel end weight
- Unique dual wheel lift lever
- Touch pad controls
- Power indicator light
- No voltage release

Options and Accessories

- Front mounted end weight assembly
- Low food fence (12"L x 1 3/8"H)
- High food fence (12"L x 3"H)
- 3" extension legs
- 10 lb. attachable portion control scale
- Clear plastic slicer cover

Standard Warranty

- 2 years parts and 1 year labor plus 15 years on the knife drive gears

Approved By: _____

Date: _____



Made in the U.S.A.



GLOBE FOOD EQUIPMENT COMPANY

www.globeslicers.com

2153 Dryden Rd.
Dayton, OH 45439
Phone: 937-299-5493
Phone: 800-347-5423
Fax: 937-299-4147



Automatic Frozen Meat Slicer

3850PF

Specifications

Finish: Exclusive all stainless steel base with radiused corners improves sanitation and durability. Other stainless steel parts include the food chute, slicing table, end weight, and knife cover.

Knife Motor: Powerful 1/2 HP, 7 amp, 115/60/1. **Chute Motor:** Two speed DC fractional horsepower 1 amp. Both motors have permanently lubricated sealed ball bearings.

Knife Drive: Cross axis helical gear drive design, which is continuously lubricated in an oil bath, ensures quiet operation and superior cutting performance when slicing frozen meat.

Slice Thickness: Precision dual gear design eliminates table movement during slicing. Consistently produces tissue thin slices with a maximum slice thickness of 1 1/4" thick.

Antimicrobial Protection: Knobs and handles have antimicrobial protection built in, which inhibits the growth of bacteria and provides superior sanitation.

Full Gravity Feed: Full 45° angle feed requires less mechanical pressure. Equipped with a 3 lb. stainless steel end weight to minimize waste and hold product. Food chute handle is ergonomically designed and the end weight swings away for storage behind the chute.

Table: EZ-Glide™ adjustable slicing table is designed to reduce surface friction, facilitating a smooth and easy slicing stroke.

Dual Wheel Lift Lever: A handle activates two large wheels, lifting the front of the unit to facilitate safe and easy cleaning underneath the slicer.

Knife Cover Interlock: Slicer will not operate with knife cover removed.

Knife Ring Guard: Permanently mounted knife ring guard covers the non-slicing portion of the knife protecting the operator from the knife's edge.

Serrated Knife: 13" diameter special hardened steel alloy serrated knife with stain resistant finish and sanitary hub easily slices through frozen meat. Knife's edge has a Rockwell hardness of 60-62.

No Voltage Release: Prevents inadvertent reactivation of slicer in the event of power or interlock interruption.

Cutting Capacity: Width 11.6" (29.5cm), Height 9" (22.9cm), Diameter 7.5" (19cm)

Power Indicator Light: A readily visible red light illuminates when the knife is rotating.

Automatic Chute: Chute travels 40 and 60 strokes per minute utilizing a separate DC motor with a heavy duty permanently lubricated chain and sprocket drive system. Chute can be quickly engaged or disengaged for manual operation with the auto engage lever.

Touch Pad Controls: Start/stop touch pad controls activate the knife motor.

Chute Speed: Controlled by faster/slower touch pad controls.

Cord & Plug: Attached 7 foot flexible 3 wire cord with molded plug fits a grounded receptacle.

Dimensions:

Foot Print = 14" x 21.6"

(35.6 cm x 54.9 cm)

Overall Length = 26.2" (66.5 cm)

Overall Width = 22" (55.9 cm)

Overall Height = 25.2" (64 cm)

Freight Class: 77.5

Net Weight: 148 lbs. (67.1 kgs.)

Shipping Weight: 175 lbs. (79.4 kgs.)

Shipping Dimensions:

28"W x 25"D x 34"H

(71.1cm x 63.5cm x 86.4cm)

Factory Installed Options:

FMEW Front mounted end weight

Accessories:

1326 High fence (12" x 3")

1047 Low fence (12" x 1 3/8")

873-SET 3" extension legs

PS13 10 lb. attachable portion control scale

SC-GLOBE Clear plastic slicer cover

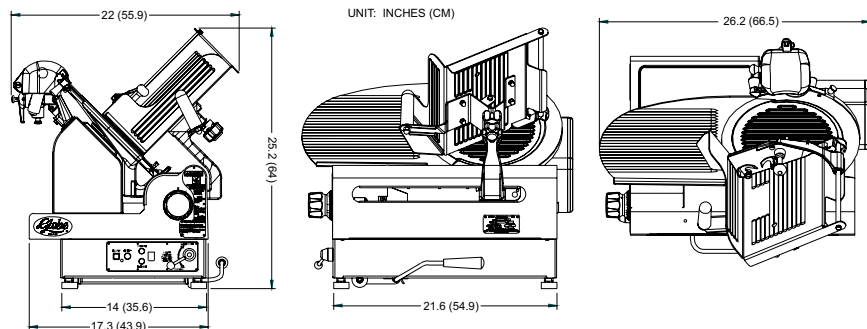

GLOBE FOOD EQUIPMENT COMPANY

www.globeslicers.com

2153 Dryden Rd.
Dayton, OH 45439
Phone: 937-299-5493
Phone: 800-347-5423
Fax: 937-299-4147

Printed in U.S.A. 11-2007

Specifications are subject to change without notice.