

## ZONE-3 SELF-SERVICE DISPLAY CASE

CUSTOMER SERVICE: 800.387.6847

*Eliminates guesswork by using a patented heating system that automatically maintains product temperature above the food safety danger zone. The computer controller constantly monitors surface temperature in 12 heat zones and adjusts instantly to assure stable product temperature, texture and quality for long periods of time.*

- *12 tightly controlled heat zones* - constantly monitor and adjust surface temperature to assure holding above the danger zone (140°F) without overcooking or operator intervention for up to 4 hours.
- *Automatic warm-up* - display case warms up to holding temperature and notifies operator when ready to safely accept product.
- *Easy to use controls and timers* - operation is made easy with simple controls. The unit warms itself up to holding temperature and notifies the operator when ready to safely accept product. A timer counts down the holding time of 2 separate product batches and notifies the operator when each is held for its maximum user-defined limit.
- *Illuminated signs* - high visibility and easy access allow customers to quickly choose product. Illuminated backlit signs attract customers from far away and promote products, prices or specials. Lights and mirrored service doors display food beautifully while minimizing condensation on domes.
- *Self-diagnostic controller* - logs temperature, operation and equipment fault data for greater control and fast troubleshooting. Alarm notifies operator in event of potential loss of safe holding temperature.
- *Fast and easy service* - modular construction makes servicing easy. The heating system components are less expensive than other brands to repair and/or replace. Glass is removable for easy cleaning.



### FEATURES

- Large capacity easily accommodates up to 20 whole chickens in domes without stacking or piling.
- All stainless steel and glass construction of holding cavity for fast and easy clean-up.
- Base can be color-matched to existing and new decorative themes.
- Electronic timer.
- 2-year parts and labor warranty

### OPTIONS

- Stainless steel or painted base.



*The Food Systems Resource*

**Hardt Equipment Manufacturing**  
2025 52 Avenue, Lachine, Montreal, QC, Canada H8T 3C3  
Tel.: (800) 387-6847 (514) 631-7271  
Fax: (514) 631-7273 Web: <http://www.hardt.ca>



## ZONE-3 SPECIFICATIONS

CUSTOMER SERVICE: (800) 387-6847

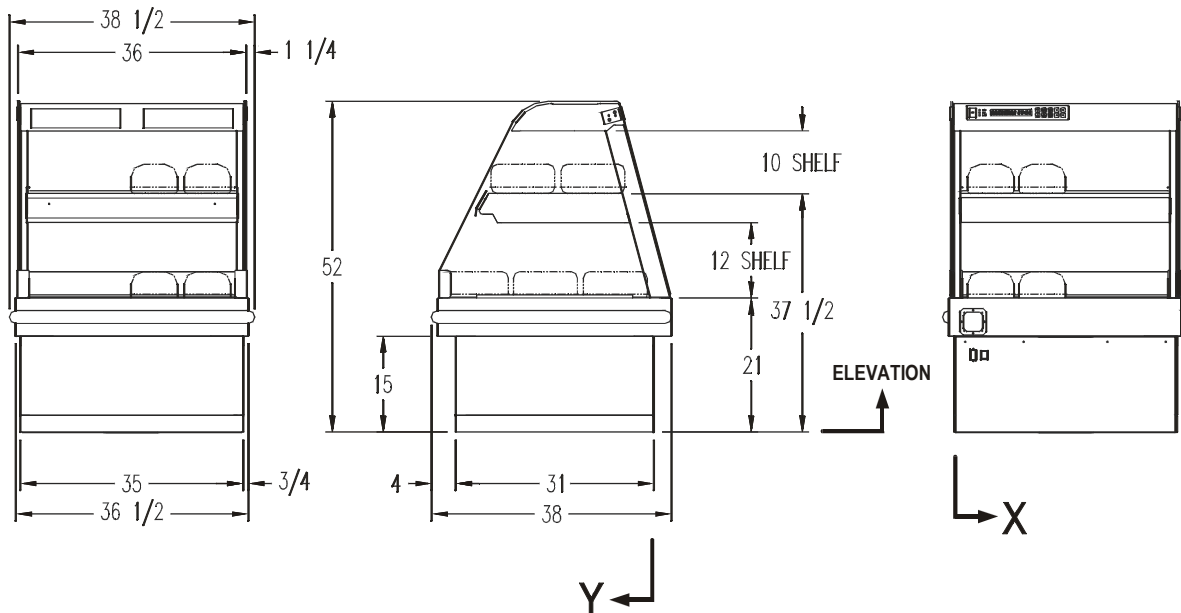

### NOTE

- 1) **Capacity:** 20 chicken domes
- 2) **Shipping weight:** Approx. 450 lbs.
- 3) **Electrical connection:** 208 VAC, 1 PH, 60 Hz, 2150 W or 240 VAC, 1 PH, 60 Hz, 2500 W.
- 4) **Lighting:** 16 x 100 W incandescent, Type A, Clear, Teflon coated.

### ELECTRICAL CONNECTION

X-Position 17"  
Y-Position 7"  
Elevation 4"

### ELECTRICAL OPENING IN BASE

X-Position 20"  
Y-Position 2"  
Elevation 3"



### WARRANTY CONDITIONS:

HARDT EQUIPMENT warrants its products to be free from defects in materials and workmanship under normal use and service for a period of two (2) years, either from the date of original installation or 8 weeks after the display case is shipped, whichever comes first. This warranty is applicable to the original end user and is not transferable.

*Hardt improves its products continuously and reserves the right to change specifications without notice.* © HARDT 2000.