



3600 Manual Slicer

SPECIFICATIONS

MOTOR: Powerful 1/2 HP 115-60-1:7 AMP, air cooled, permanently lubricated sealed ball bearings. Solid state start relay.

ON/OFF TAB: Moisture protected toggle type, operated by a push-pull rod.

RED INDICATOR LIGHT: A readily visible light illuminates when knife is rotating.

CORD & PLUG: Attached 7 foot flexible 3 wire cord and plug fits a grounded receptacle.

FINISH: EXCLUSIVE ONE PIECE #304 STAINLESS STEEL base with radiused corners improves sanitation and durability. Other stainless steel parts include the food chute, slicer table, end weight, and knife cover.

HOLLOW GROUND KNIFE: Nominal 12" diameter special hardened steel alloy with stain resistant finish and sanitary hub.

TOP MOUNTED SHARPENER: Sharpener is made of all metal and is permanently mounted on the slicer. A single lever activates the large grinding and honing stones.

KNIFE DRIVE: Cross axis helical gear drive design. This positive drive design assures non-slip, trouble free operation.

KNIFE RING GUARD: Permanently mounted knife ring guard protects the non-slicing portion of the knife. Slicer table protects leading edge of knife when completely closed.

KNIFE COVER INTERLOCK: Slicer will not operate with knife cover removed.

FULL GRAVITY FEED: Full 45° angle feed requires less mechanical pressure. Equipped with a 3 lb. STAINLESS STEEL end weight to minimize waste and hold product. The end weight swings away for storage behind chute. The food chute handle is ergonomically designed.

CAPACITY: Holds round pieces up to 7-1/2" (19 cm) in diameter and flat pieces up to 12" (30 cm) in width.

SLICE THICKNESS: Precision gear adjustment holds thickness setting for consistent cuts and allows hot or cold foods to be sliced from tissue thin up to 1-1/4" thick.

CLEANING BRACE: A metal brace under the slicer drops into position, tilting the slicer to facilitate countertop cleaning.

NO VOLTAGE RELEASE: Prevents inadvertent reactivation of slicer in the event of power or interlock interruption. Operator must restart slicer.

FACTORY INSTALLED OPTIONS:

- Various 60 & 50 cycle motors
- End weight with prongs
- 17" food chute in lieu of 12"
- Stainless steel knife
- Front mounted endweight on 12" chute
- 3" extensions legs
- Aluminum Food Chute

OPTIONAL ACCESSORIES:

- Vegetable Hopper
- Bagel Chipping Attachment
- Adjustable Stainless Steel Food Fences
- Portion Scale
- Slicer Cover

DIMENSIONS:

FOOT PRINT = 13 3/4" x 21 1/4"
(35 cm x 54 cm)

OVERALL LENGTH = 25" (64 cm)

OVERALL WIDTH = 22" (56 cm)

OVERALL HEIGHT w/FEET = 21" (53 cm)

Freight Class: 77.5

Net Weight: 103 lbs. (47 kg)

Shipping Weight: 135 lbs. (61 kg)

Box Dimensions: 33W x 26D x 30H



Made in the USA

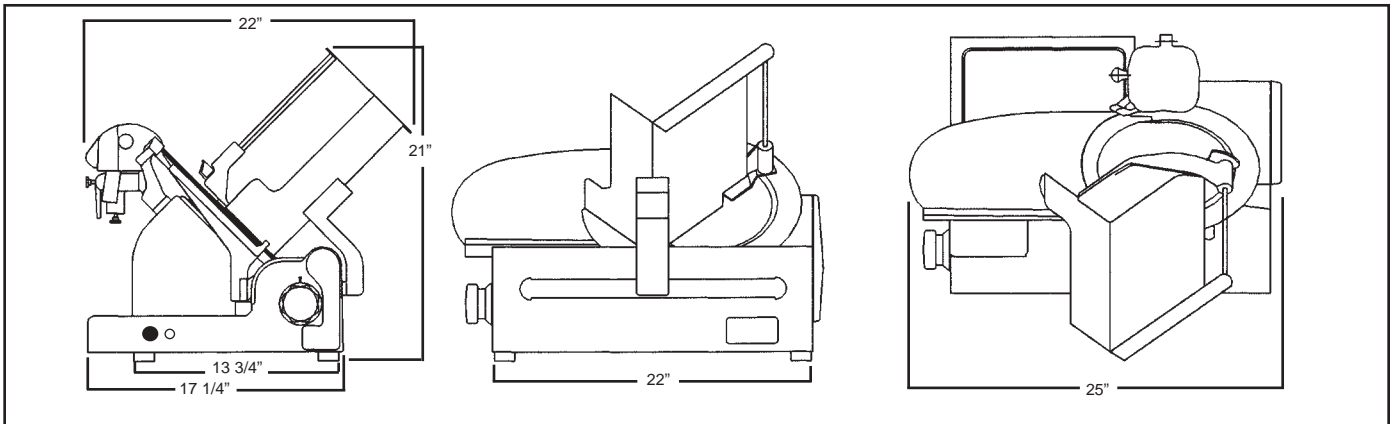

GLOBE FOOD EQUIPMENT CO.

P.O. BOX 3209
DAYTON, OH 45401-3209
PHONE: 937/299-5493
1-800-347-5423
FAX: 937/299-4147

Specifications are subject to change without notice

E-MAIL: globeinfo@globeslicers.com
Visit our Web Site: www.globeslicers.com