

MARK V

CUSTOMER SERVICE: (800) 387-6847

The Mark V's all stainless steel construction contains our Dual Rotation Skewer System where both the skewers and the drive rotate simultaneously. This ensures a consistent product and eliminates skewer handling during the cooking process.

Hardt's gas-fired Infrared Burner penetrates quickly into the product to avoid dryness, ensuring a thoroughly cooked product. The radiant heat melts the fatty layer beneath the skin to allow the product to be self-basting.

The water pan that is built into the bottom of each rotisserie serves a dual function as a humidifier as well as a cleaning aid. The water that evaporates during the cooking cycle provides a 'moist' environment that maximizes yield by minimizing shrinkage. The water pan also catches the grease drippings and prevents them from becoming baked onto the bottom surface of the rotisserie.



The Mark V is also available in a double deck format.



CAPACITY

42 chickens (may vary according to the drive configuration and bird size)

STANDARD FEATURES

| | |
|-----------------|-------------------------|
| Thermometer | Basic plumbing hardware |
| Adjustable legs | 7 "V" skewers |
| Owner's manual | Drain Strainer |

OPTIONS

Casters
6 or 7 spit drives (at no additional cost)
Water & Gas quick disconnect kits
Smoker attachment

ACCESSORIES

| | |
|------------------------|-------------------------------|
| Roast skewer | Multi-purpose standard basket |
| Additional "V" skewers | Multi-purpose large basket |
| Turkey skewer | Hanging basket |
| Skewer rack | Oversized basket |
| Skewer rack cover | Skewer forks |
| Hanging skewer rack | Skewer container |
| Preparation table | Spice crank |

WHEN ORDERING

Please specify the gas type (i.e. natural gas or propane), site elevation, the electrical requirements, the preferred drive configuration, as well as which options and accessories are required.



The Rotisserie Systems Specialists

Hardt Equipment Manufacturing
2025 52nd Avenue, Lachine, Montreal, QC, Canada H8T 3C3
Tel: (800) 387.6847 (514) 631.7271
Fax: (514) 631.7273 Web: <http://www.hardt.ca>



MARK V SPECIFICATIONS

CUSTOMER SERVICE: (800) 387-6847

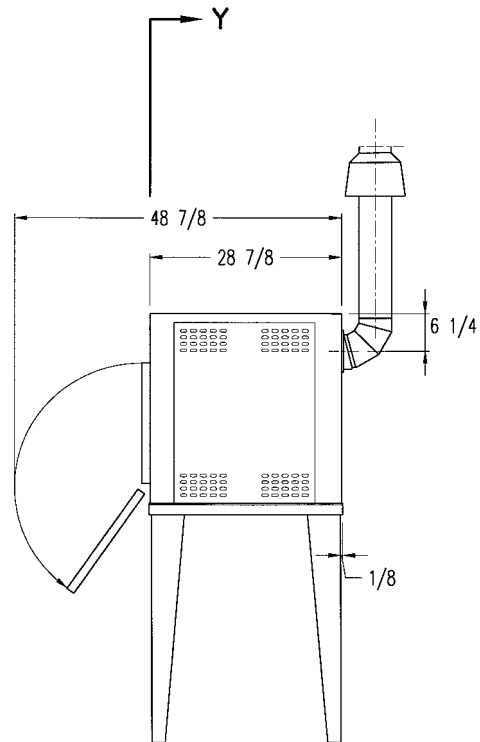
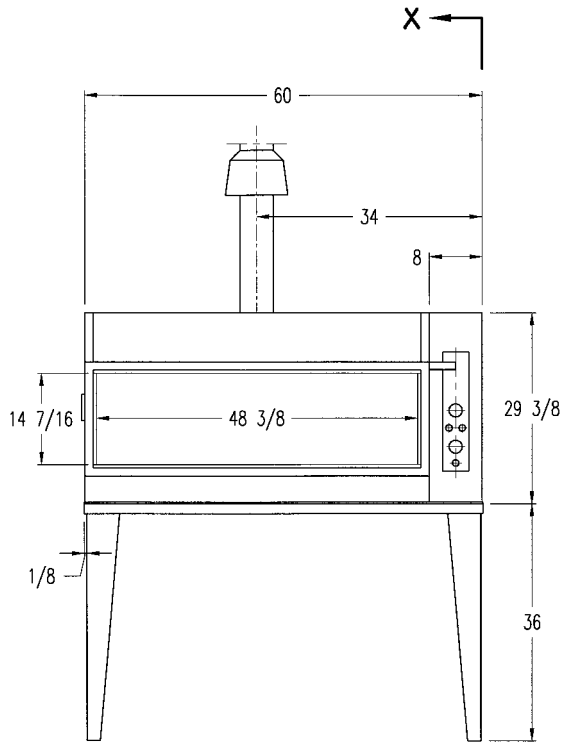

CONNECTIONS

Gas: *Minimum supply pressure:*

Natural: 7" WC

Propane: 11" WC

Manifold pressure:

Natural: 6" WC

Propane: 10" WC

Maximum rating: 75,000 Btu/h

Connection: 1/2" NPT Male

Electrical: 120V 1PH 60Hz 7.5A

Venting: 5" diameter, 20.25" height.

Flue under hood/canopy or direct.

For direct vent use draft control

as specified in owner's manual.

Not suitable for connection to type B gas vent.

Water Inlet: 1/2" NPT coupling (preferably hot water)

Drain & Overflow: 1 1/2" connection

SHIPPING WEIGHT

Approx. 750 lbs.

CLEARANCES

Control Side (right): 12"

Opposite Side (left): 2"

Back: 10"

| FEATURE | X-POSITION | Y-POSITION | ELEVATION |
|------------------------|------------|------------|-----------|
| Drain Connection | 17 5/8 | 9 1/4 | 36 |
| Electrical Connection | 1 3/8 | 6 1/2 | 37 1/2 |
| Gas Connection | 4 1/8 | 7 1/2 | 37 1/2 |
| Over Flow Connection | 11 5/8 | 9 1/4 | 36 |
| Water Inlet Connection | 7 3/8 | 26 3/4 | 38 1/2 |

All measurements are in inches.



WARRANTY CONDITIONS:

HARDT EQUIPMENT warrants its products to be free from defects in materials and workmanship under normal use and service for a period of two (2) years, either from the date of original installation or 8 weeks after the rotisserie is shipped, whichever comes first. This warranty is applicable to the initial end-user and is not transferable.

Hardt improves its products continuously and reserves the right to change specifications without notice. © HARDT 1999